

DIRECTIONAL CONTROL VALVES 13ST(F) – 6-WAY

GENERAL DESCRIPTION

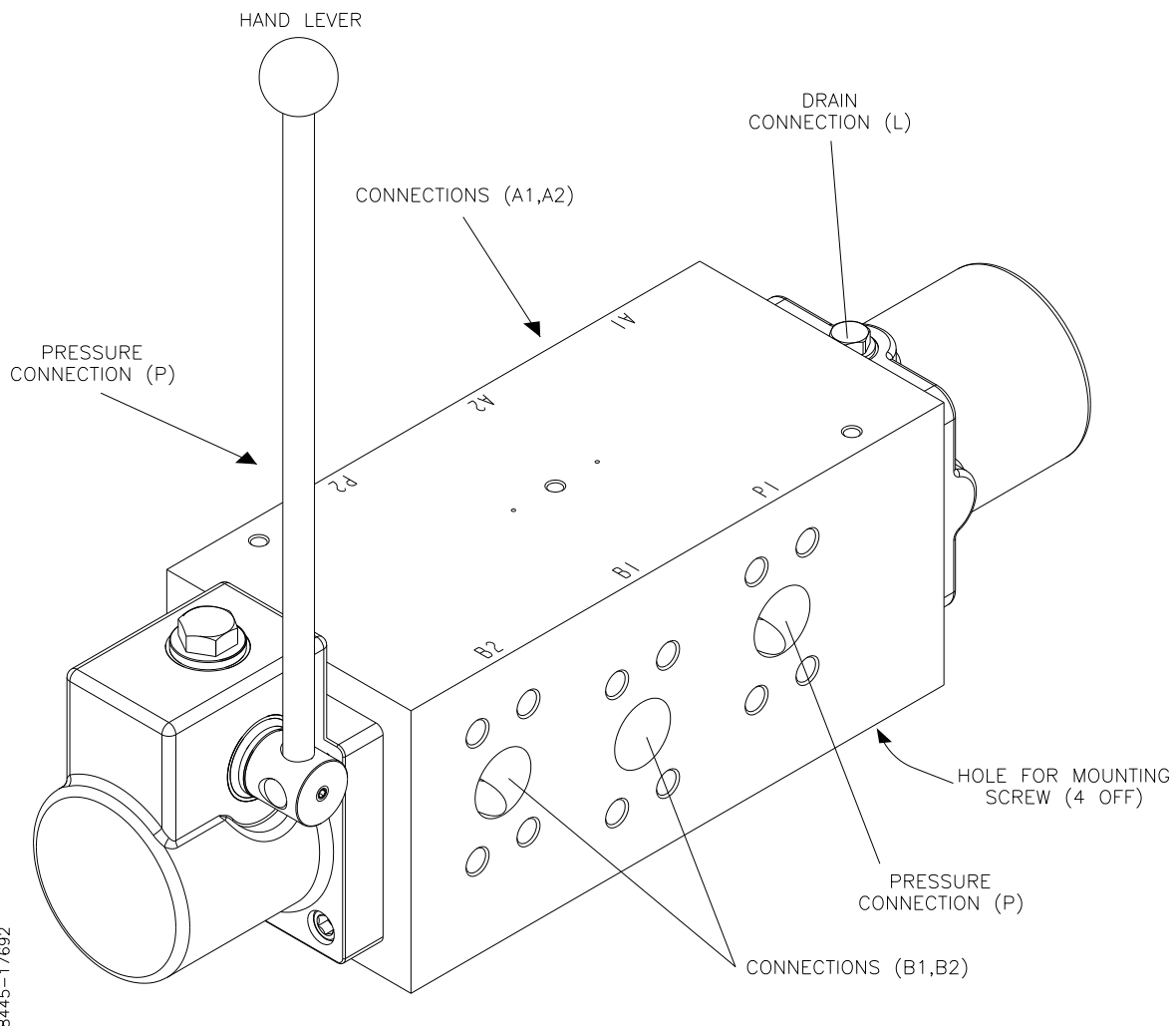

Figure 1 13STF General Arrangement

The Directional Control Valves 13ST(F) 6-ways are seawater resistant valves for smooth distribution and stopping of flow in hydraulic systems. The valves have the following characteristics:

- Delivered with SAE flanges.
- Proportional controlled manually with the hand lever, or remote controlled (on/off) by hydraulic pilot pressure.
- Delivered with flow capacity up to 1000 l/min.
- Most of the hand lever operated directional control valves can be equipped with the Brake Release Valve BA3/BA4. For description of the Brake Release Valves, please refer to separate manual.

For more details about types and options, please refer to section 'Modular Code'.



MODULAR CODE

Options	Remarks	Design Code	Fill in
Mounting			13ST
Flange	SAE	F	F
Type			
6-ways	No options	6	6
Pressure			
210 bar		3	3
350 bar		4	4
Operation			
Manual		1	
Remote		2	
Size			
30 mm	450 l/min	6	
40 mm	700 l/min	8	
50 mm	1000 l/min	B	
Spool Type			
	No options	6V	6V
Spring / Detents Positions			
Detents in position B and 0, A blocked		7	
Spring offset to B, A blocked		8	
Modification			
Without throttle plate		0	
Pilot pressure throttled		A	

In example a 13ST 6-way valve with flanges, remotely controlled, 700 l/min flow, spring offset to B, A blocked and with pilot pressure throttled will have the following modular code: **13STF64286V8A**.

Manual Version

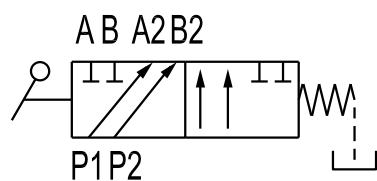

Remote Version

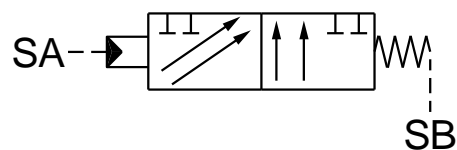

DIMENSIONS

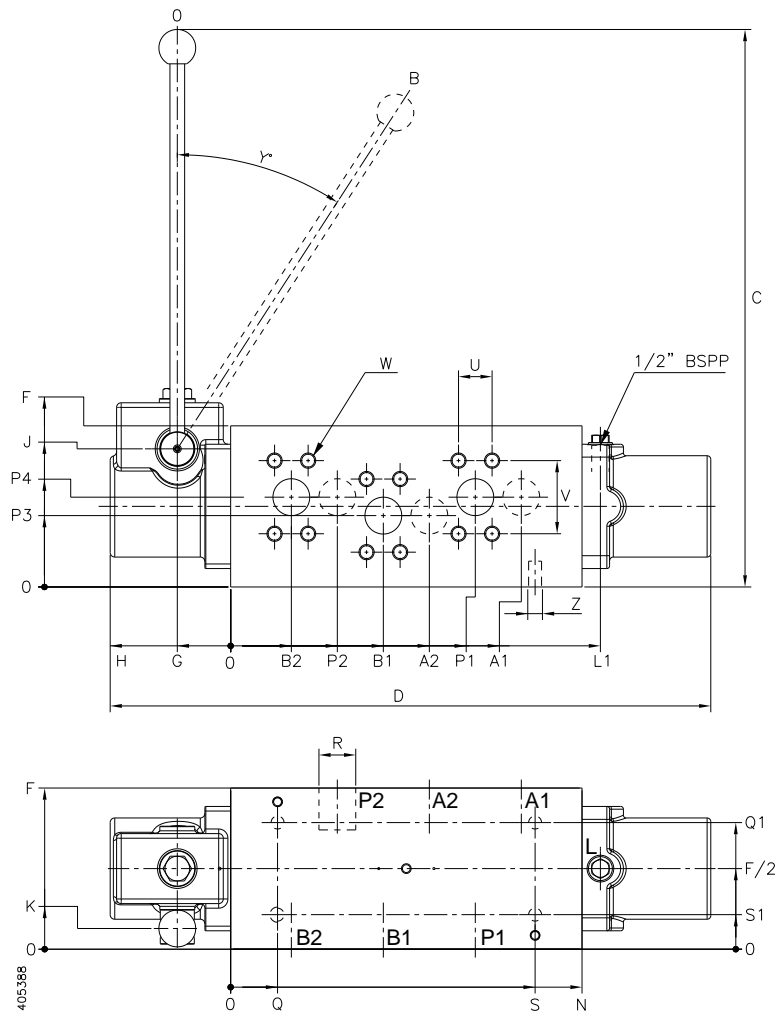

Figure 2 13STF Dimensions

Common dimensions for 13STF 631** and 641****:**

Size [mm]	C	D	F	G	H	J	K	N	Y°
30	424	529	128	52	102	109	14	315	37
40	609.5	653	175	88	131	150	4.5	382	33
50	700	805	200	100	160	159	9	470	36

13STF 631**:**

Size [mm]	A1	A2	B1	B2	L1	P1	P2	Q	Q1	S	S1	U	V
30	255	177	138	60	335	216	99	40	110	275	18	35.7	69.8
40	316	216	166	66	402	266	116	51	187.5	331	37.5	50.8	88.9
50	385	265	205	85	504	325	145	45	170	425	15	50.8	88.9

13STF 641**:**

Size [mm]	A1	A2	B1	B2	L1	P1	P2	Q	Q1	S	S1	U	V
30	255	177	138	60	335	216	99	40	110	275	18	31.8	66.7
40	316	216	166	66	402	266	116	51	187.5	331	37.5	36.5	79.4
50	385	265	205	85	504	325	145	45	170	425	15	44.5	96.8

PRESSURE DROP

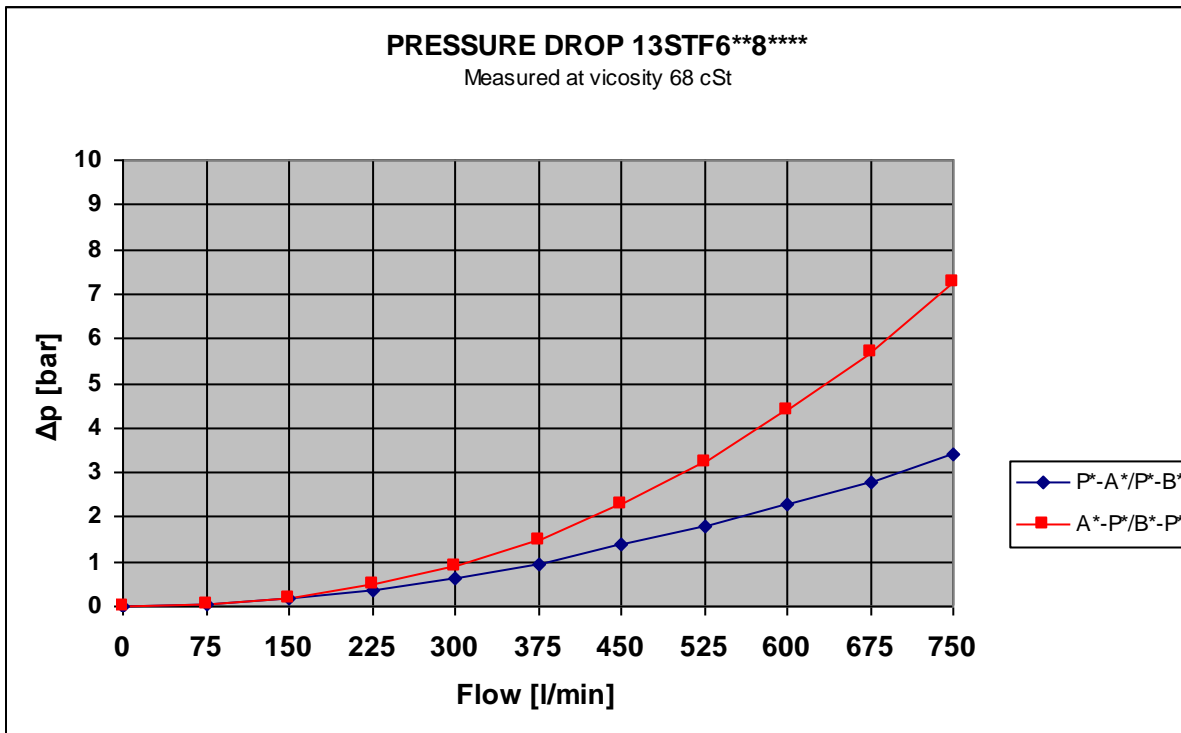
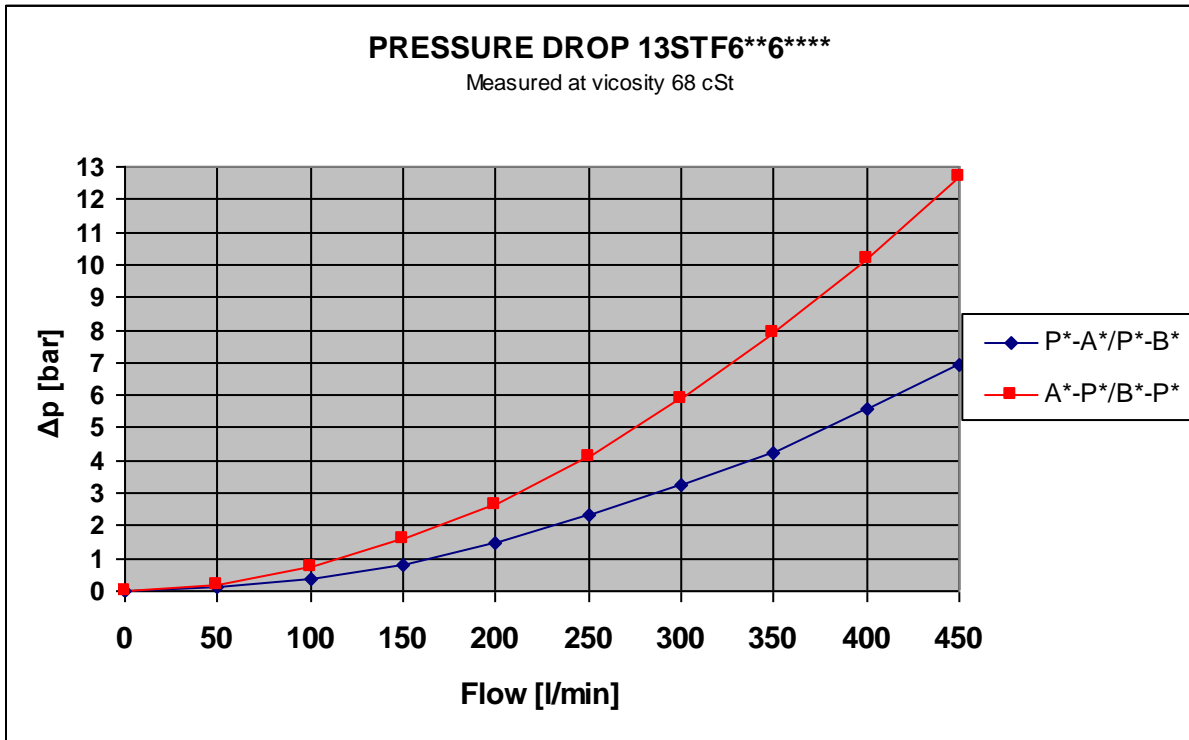

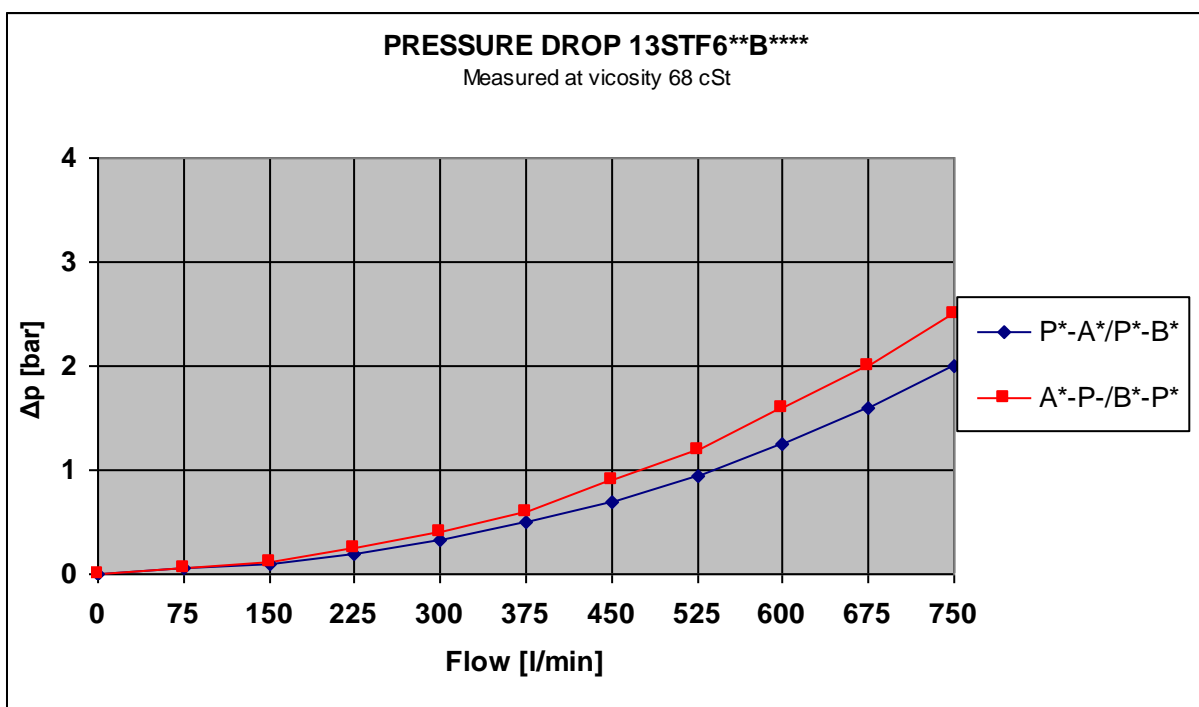

TECHNICAL DATA

Description	Symbol	Data
Max. operating pressure in port P, A, B (Pressure code 4, 350 bar)	P_{nom}	350 bar
Max. operating pressure in port P, A, B (Pressure code 3, 210 bar)	P_{nom}	210 bar
Test Pressure	P_{max}	420 bar
Max pressure in L (manual version)	L_{max}	30 bar
Min pilot pressure SA (remote version)	SA_{min}	4 bar
Max pilot pressure SA (remote version)	SA_{max}	160 bar
Hydraulic fluid		Mineral oils for hydraulic system
Viscosity range:	ν	10 to 350 mm ² /s (cST)
Viscosity index:	VI	> 120
Filtration, recommended filter with $\beta_{20} \geq 100$		Class 9 according to NAS 1638, 18/15 according to ISO 4406
Fluid temperature range:	T	-20°C to + 70°C
Ambient temperature range	T	-20°C to + 50°C
Standard Body Material		EN-GJS-400-15 (GGG 40)
Standard O-rings		Nitrile shore 70

When pressure on connection T exceeds 30 bar, drain connection (L) must be used.

Flow and Weights:

Size	Max. Flow	Weight
30 mm	450 l/min	48 kg
40 mm	700 l/min	100 kg
50 mm	1000 l/min	150 kg



Interfaces:

Size	Description		Data
13STF63*****:			
	<i>Flanges</i>	<i>Screws</i>	<i>Tightening Torque [Nm]</i>
30 mm	1½” SAE 3000	M 12 – DIN931	54.0
40 mm	2” SAE 3000	M 12 – DIN931	54.0
50 mm	2 ½” SAE 3000	M 12 – DIN931	54.0

Size	Description		Data
13STF64*****:			
	<i>Flanges</i>	<i>Screws</i>	<i>Tightening Torque [Nm]</i>
30 mm	1½” SAE 6000	M 16 – DIN931	78.5
40 mm	2” SAE 6000	M 16 – DIN931	78.5
50 mm	2 ½” SAE 6000	M 20 – DIN931	110



INSTALLATION

The Directional Control Valves 13STF are installed to the pipeline with SAE flanges and mounted to a bracket or similar with 4 off screws. Please refer to 'Interfaces', for details about connections and screws.

OPERATION

Manual

Manual control is performed by the hand lever. If the valve is delivered with centring spring the spool will return to the neutral position after operating the hand lever. If the valve has detents the spool will remain in the position set by hand lever.

Remote

In the remote controlled valves, an external pilot pressure moves the spool to the requested position – on/off.

MAINTENANCE

Check the valve for proper function. Visually check the valve and if required, paint unpainted (damaged) areas.

CAUTION: Do not paint the hand lever shaft seal.

STORAGE

If storage longer than 6 months is expected, the valve must be kept in a dry room, free from dust and protected against sudden large temperature variations. For storage longer than 12 months, the valve must be filled with inhibition oil. Before use check all visible seals and flush with clean oil.

MARKING

Inlets and outlets are marked, refer to figure in section 'General Description'.