

DIRECTIONAL CONTROL VALVES 20ST(F)(B) – 4-WAY

GENERAL DESCRIPTION

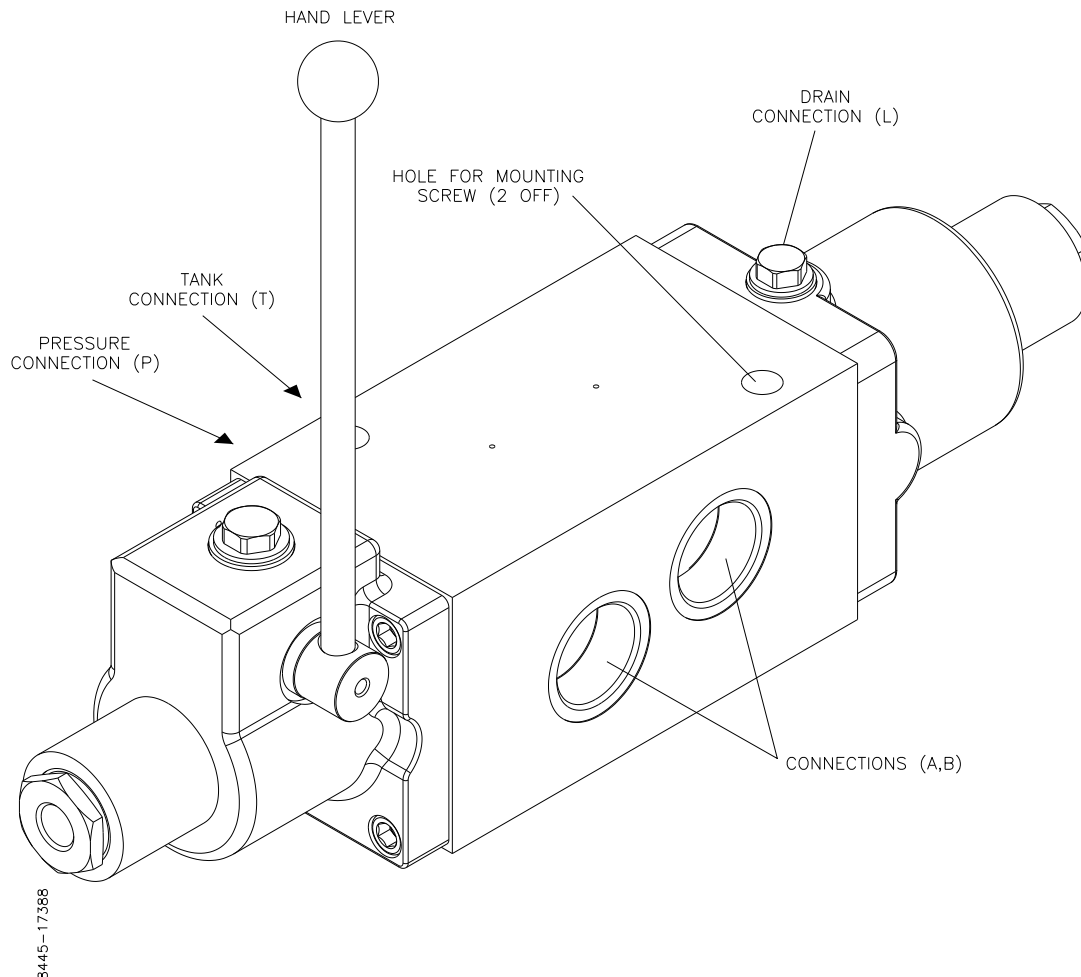

Figure 1 20ST General Arrangement

The Directional Control Valves 20ST(B) 4-ways are seawater resistant valves for smooth distribution and stopping of flow in hydraulic systems. The valves have the following characteristics:

- Delivered with threaded connections, SAE flanges or for gasket mounting to a sub plate or valve unit.
- Proportional remotely controlled by hydraulic pilot pressure.
- Manual override by the hand lever.
- Delivered with flow capacity up to 700 l/min.
- Six standard spools with throttling grooves for smooth start and stop are available.
- Most of the hand lever operated directional control valves can be equipped with the Brake Release Valve BA3/BA4. For description of the Brake Release Valves, please refer to separate manual.

For more details about types and options, please refer to section 'Modular Code'.



MODULAR CODE

Options	Remarks	Design Code	Fill in
Mounting			20ST
Threads			
Flange	SAE 6000, Note1	F	
SUB Plate		B	
Type			
4-ways	No options	4	4
Pressure			
350 bar	No options	4	4
Operation			
Manual/ Proportional Remote		7	
Size			
20 mm	200 l/min	4	
25 mm	300 l/min	5	
30 mm	450 l/min	6	
40 mm	700 l/min	8	
Spool Type			
		01	
		02	
		03	
		07	
		2C	
Spring / Detents Positions			
Spring centred		1.	1.
Remote control pressure			
8-30 bar			
8-45 bar (recommended for spool -01)		2AC	

In example a 20ST valve with sub plate, 300 l/min flow, spool type 06 and remote control pressure 8-45 bar will have modular code: **20STB44752C061.2AC**.

Note1: For 20STF SAE 3000 flanges to be delivered upon request.

DIMENSIONS

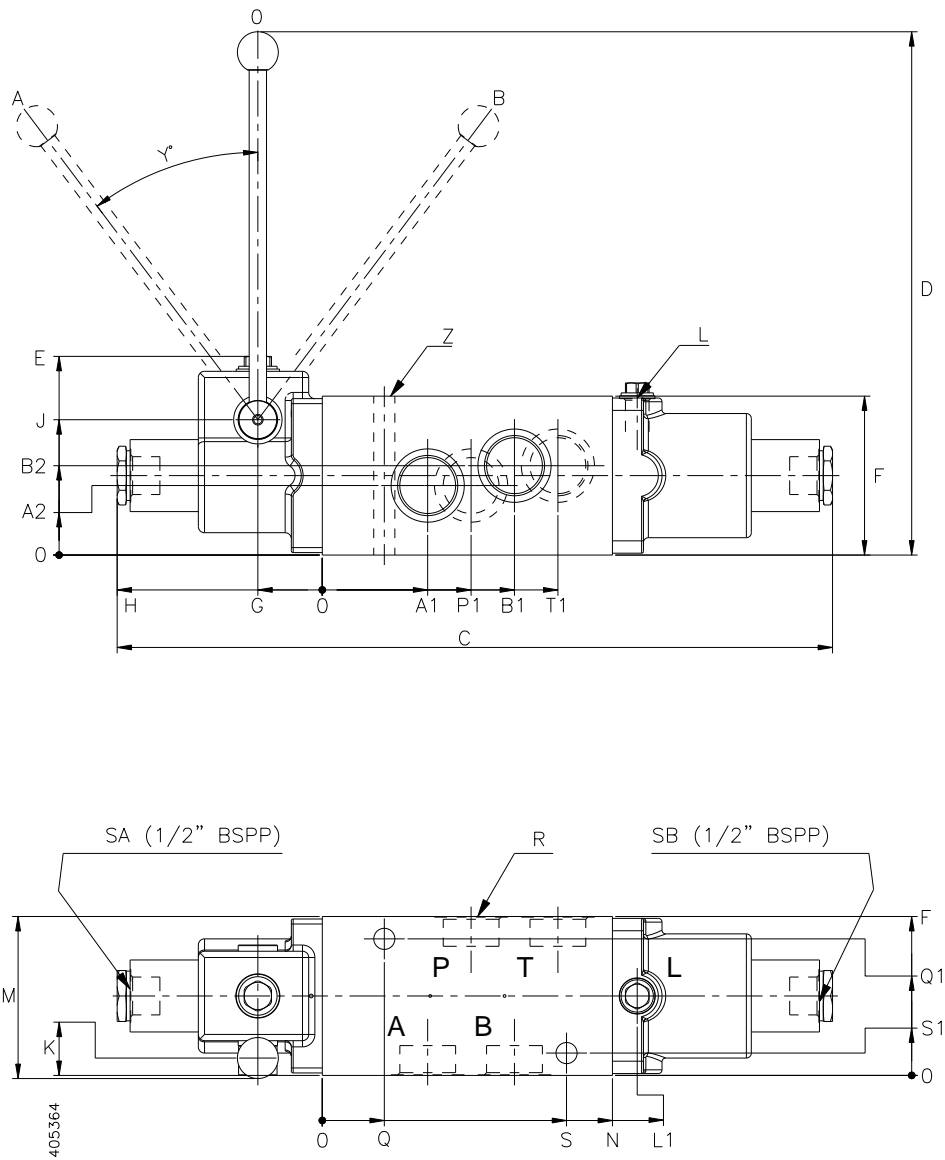

Figure 2 20ST Dimensions

Common dimensions for 20ST, 20STF and 20STB:

Size [mm]	C	D	F	G	H	J	K	N	Z	Y°
20	419	336	95	33	126	79.5	8.5	158	13	35
25	437	350	118	33	126	91	20	176	13	35
30	578	425	128	52	167	109	14	234	17	37
40*	785	424	175	58	232	137.5	22.5	328	17	33

*Some of the dimensions varies for the models B, E, D and F.

20ST:

Size [mm]	A1	A2	B1	B2	L1	P1	T1	Q	Q1	S	S1
20	55	32.5	103	62.5	172	79	127	25	83.5	133	11.5
25	55	40	107	78	190	81	133	25	104	156	14
30	85	56	155	72	254	120	190	50	110	197	18

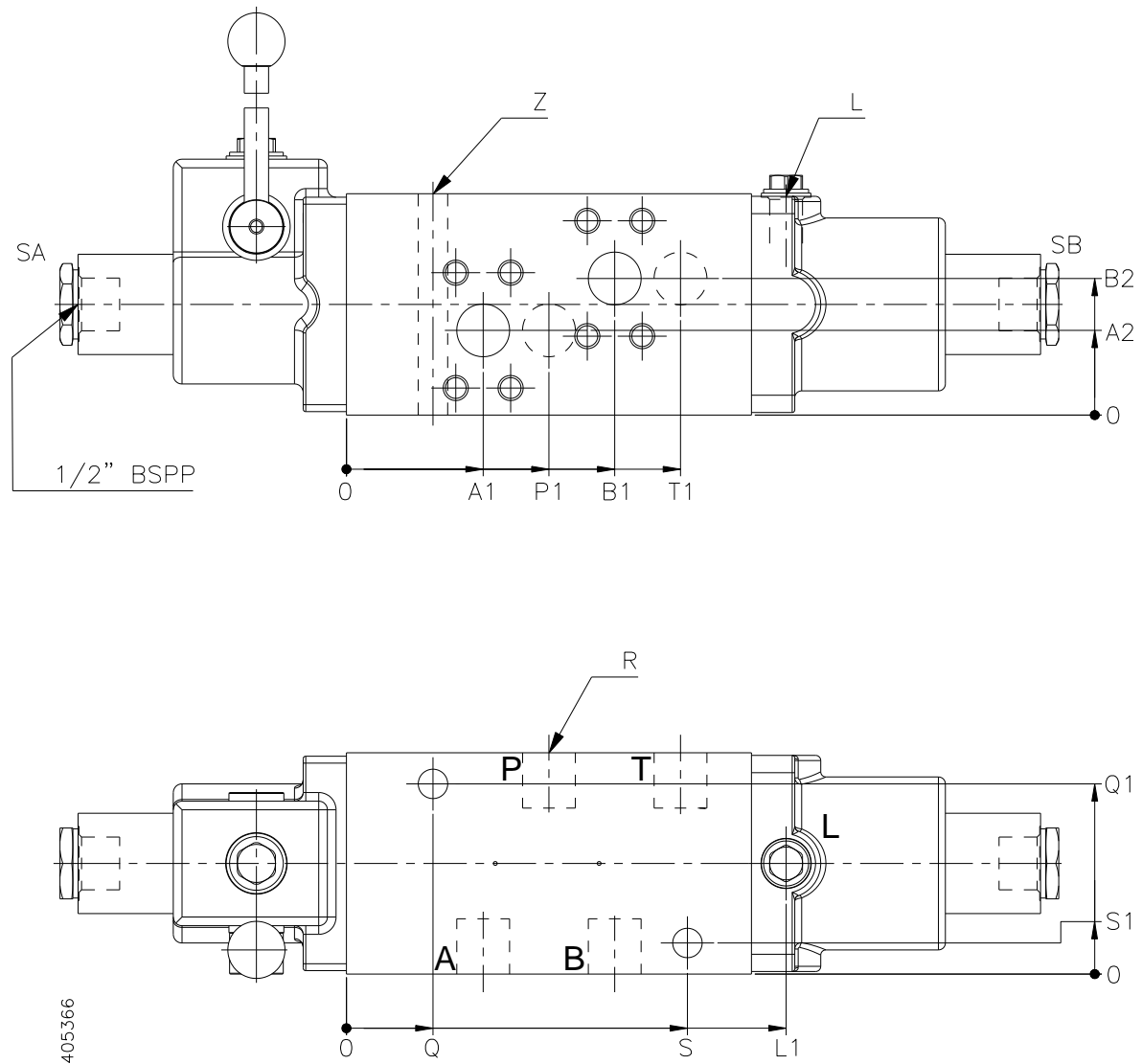

Figure 3 20STF Dimensions

20STF:

Size [mm]	A1	A2	B1	B2	L1	P1	T1	Q	Q1	S	S1
30	80.5	49	159.5	79	254	111	190	50	110	197	18
40	114	77.5	214	97.5	348	164	264	60	141.5	268	33.5

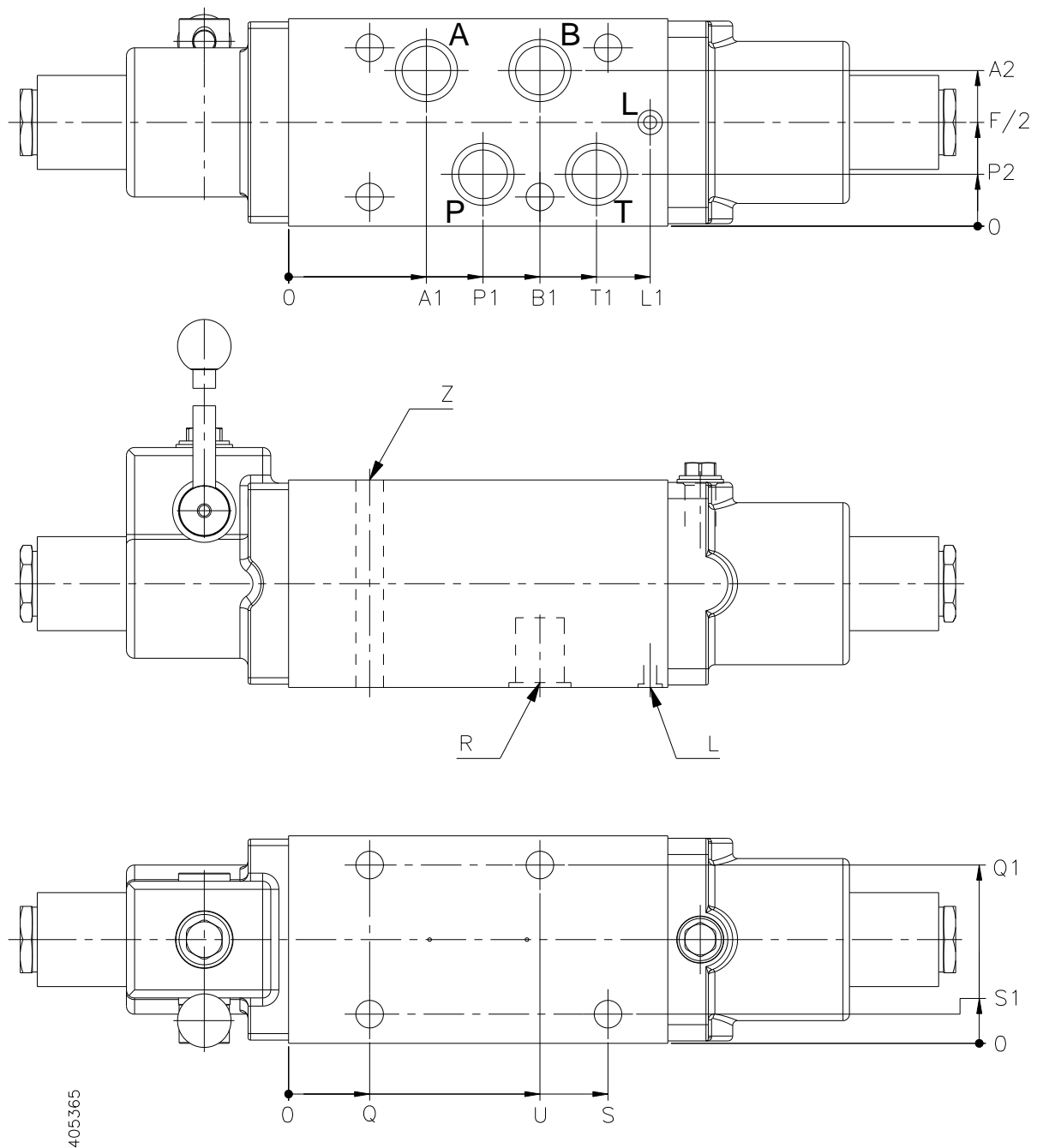

Figure 4 20STB Dimensions

20STB:

Size [mm]	A1	A2	B1	B2	L1	P1	P2	T1	Q	Q1	U	S	S1
20	55	73.5	103	144.5	47.5	79	21.5	127	25	83.5	103	133	11.5
25	55	85	107	150.5	59	81	33	133	25	104	107	139	14
30	85	96	155	223	64	120	32	190	50	110	155	197	18
40	114	137.5	214	313	87.5	164	37.5	264	60	159	264	302	16



PRESSURE DROP

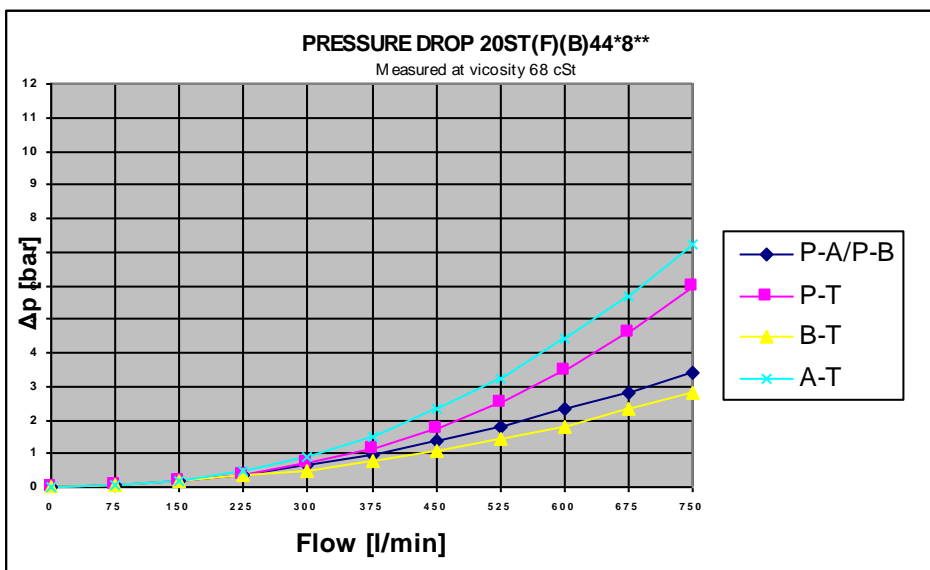
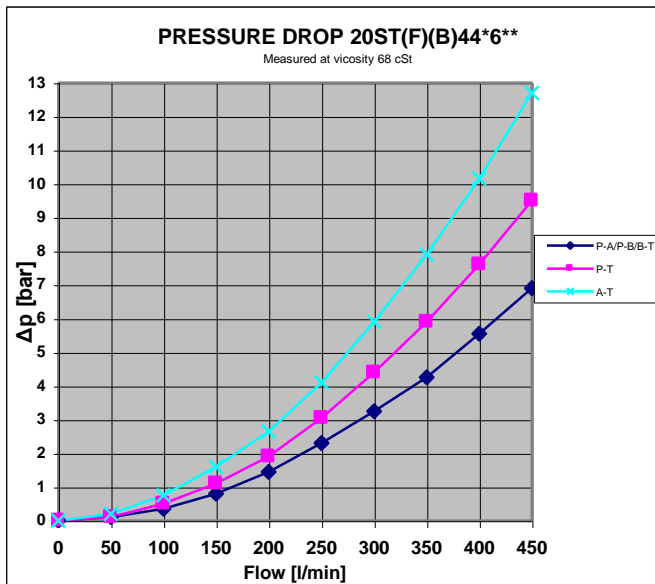
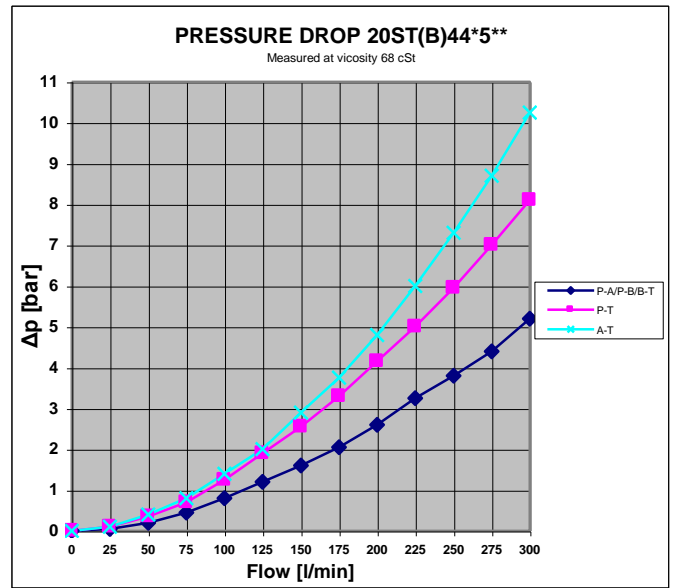
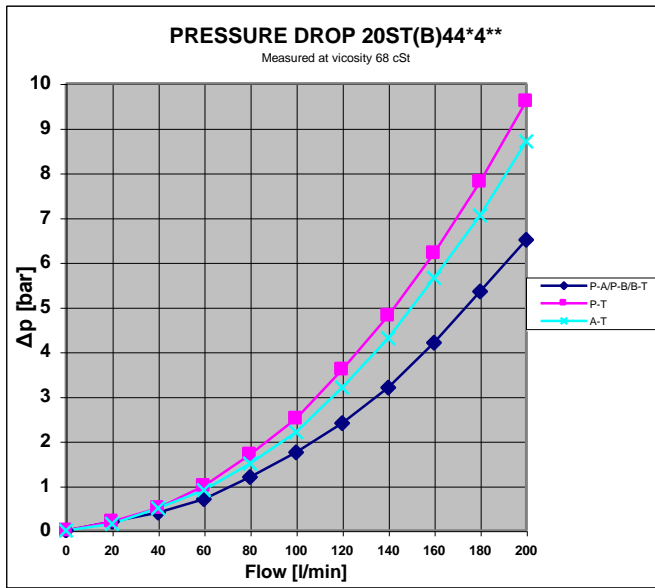



TECHNICAL DATA

Description	Symbol	Data
Max. operating pressure in port P, T, A, B	P_{max}	350 bar
Max. pressure in port L (must always be in use)	L_{max}	30 bar
Directional valve pilot pressure	SA/SB	8-30 bar / 8-45 bar
Test Pressure		420 bar
Hydraulic fluid		Mineral oils for hydraulic system
Viscosity range:	ν	10 to 350 mm ² /s (cST)
Viscosity index:	VI	> 120
Filtration, recommended filter with $\beta_{20} \geq 100$		Class 9 according to NAS 1638, 18/15 according to ISO 4406
Fluid temperature range:	T	-20°C to + 70°C
Ambient temperature range	T	-20°C to + 50°C
Standard Body Material		EN-GJS-400-15 (GGG 40)
Standard O-rings		Nitrile shore 70

Flow and Weights:

Size	Max. Flow	Weight
20 mm	200 l/min	14 kg
25 mm	300 l/min	20 kg
30 mm	450 l/min	36 kg
40 mm	700 l/min	95 kg



Interfaces:

Size	Description	Data
20ST:		
	<i>Threaded Connections</i>	<i>Mounting Screws Valve Body</i>
		<i>Tightening Torque [Nm]</i>
20 mm	1" BSPP	2 off M 12 x 110
25 mm	1¼" BSPP	2 off M 16 x 130
30 mm	1½" BSPP	2 off M 16 x 145
40 mm	2" BSPP	2 off M 16 x 200
20STF:		
	<i>SAE Flanges</i>	<i>Mounting Screws Valve Body</i>
		<i>Tightening Torque [Nm]</i>
30 mm	1¼" SAE 6000	2 off M 16 x 145
40 mm	1½" SAE 6000	2 off M 16 x 200
20STB:		
	<i>Mounting Screws Valve Body</i>	<i>Tightening Torque [Nm]</i>
20 mm	4 off M 12 x 110– DIN 931	54.0
25 mm	4 off M 16 x 130 – DIN 931	78.5
30 mm	4 off M 16 x 145 – DIN 931	78.5
40 mm	4 off M 16 x 200 – DIN931	78.5
	<i>O-rings</i>	<i>Size [mm]</i>
20 mm	4 off 1 off (manually operated valves only)	22.20 x 3.0 9.92 x 2.62
25 mm	4 off 1 off (manually operated valves only)	26.2 x 3.0 9.92 x 2.62
30 mm	4 off 1 off (manually operated valves only)	31.34 x 3.53 9.92 x 2.62
40 mm	4 off 1 off (manually operated valves only)	44.04 x 3.53 9.92 x 2.62



INSTALLATION

The Directional Control Valves 20ST(F)(B) are installed as follows:

- The 20ST valves are installed with threaded connections and mounted to a bracket or similar with 2 off screws.
- The 20STF valves are installed to the pipeline with flanges and mounted to a bracket or similar with 2 off screws.
- The 20STB valves are installed with 4 off screws to a SUB plate or valve unit.

Please refer to 'Interfaces', for details about connections, flanges and screws.

OPERATION

The 20 ST valves are proportional remotely controlled by an external pilot pressure, which moves the spool to the requested position.

The valves are equipped with a hand lever for override of the pilot pressure. The hand lever is mechanically connected to the spool.

MAINTENANCE

Check the valve for proper function. Visually check the valve and if required, paint unpainted (damaged) areas.

CAUTION: Do not paint the hand lever shaft seal.

STORAGE

If storage longer than 6 months is expected, the valve must be kept in a dry room, free from dust and protected against sudden large temperature variations. For storage longer than 12 months, the valve must be filled with inhibition oil. Before use check all visible seals and flush with clean oil.

MARKING

Inlets and outlets are marked, refer to figure in section 'General Description'.