

MODULAR UNIT 8MB

GENERAL DESCRIPTION

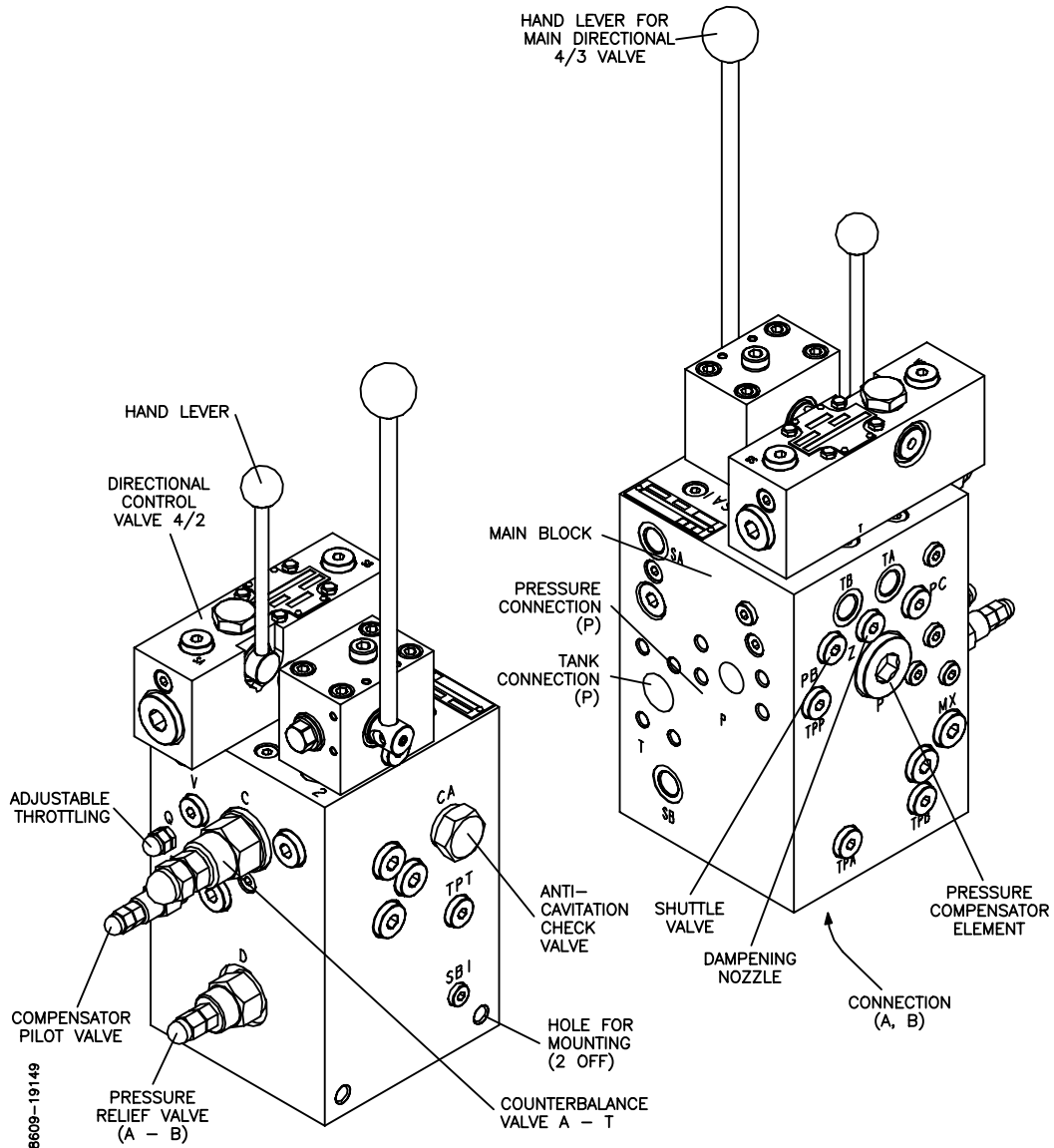

Figure 1 General Arrangement 8MB-***-**-2C-MA-T

The Modular Unit 8 MB is a complete unit for controlling of hydraulically driven winches and has the following improved characteristics:

- Extremely compact design, all valves integrated in one unit.
- Pressure compensated flow control system, which gives excellent metering.
- Designed to withstand marine surroundings.
- Hand lever with 39° control movement in each direction.
- Prepared to fit directly to different hydraulic motor flanges with an adapter.

For more details about types and options, please refer to section 'MODULAR CODE'.

MODULAR CODE

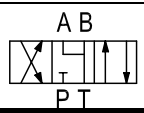
Options	Remarks	Design Code	Fill in
Standard			
- Main block		8MB	
- Directional valve			
- Pressure compensated flow control			
- Counterbalance valve in A			
- Free flow check valve (In Heave)			
- Pressure relief valve A → B	Prepared for mooring		
Size			
Pressure drop at Q = 140 l/min 32 bar	Flow area 70-140 l/min	140	
Pressure drop at Q = 220 l/min 32 bar	Flow area 140-220 l/min	200	
P: 3/4" SAE 6000			
T: 1" SAE 3000			
A, B: 1/2" SAE 6000			
Directional Control Valve 4/3			
Manually operated		1	
Manually/remote operated		37	
Manually operated with brake		1B	
Prop. electrical remote ctrl.	Includes separate R	37E	
Proportionally electrical remote	With integrated R	37ER	
Manually/remote operated with brake		37B	
Prop. electrical remote with brake	Includes separate R for Proportional valve (item E)	37BE	
Proportionally electrical remote controlled, with brake release 4BA3	With integrated R	37BER	
Spool type			
	No option	2C	
Remote control tension valve			
Tension valve A to B		MA	
Mooring valve, direct manually		MAM	
Manual control safety lock			
0 position only		L	
0 + 30% in A		L3	

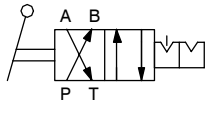
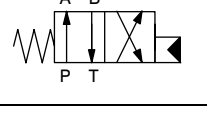
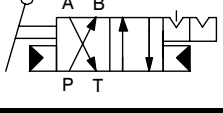
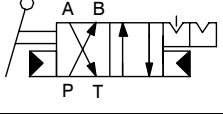
Two-speed valve			
Manual operated		T	
Manual operated with reduced pressure		TR	
Hydraulic operated		TH	
Hydraulic operated with reduced pressure		THR	
Manual/hydraulic operated		TMH	
Manual/hydraulic operated with reduced pressure		TMHR	
Pressure reducing valve only		R	
Modification			
Code		(001-999)	

In example a 8MB intend for flow 200 l/min, manually operated main directional control valve, manual operated two-speed valve will have modular code: **8MB-200-1-2C-MA-T**

VALVE DESCRIPTION 8MB (basic version)

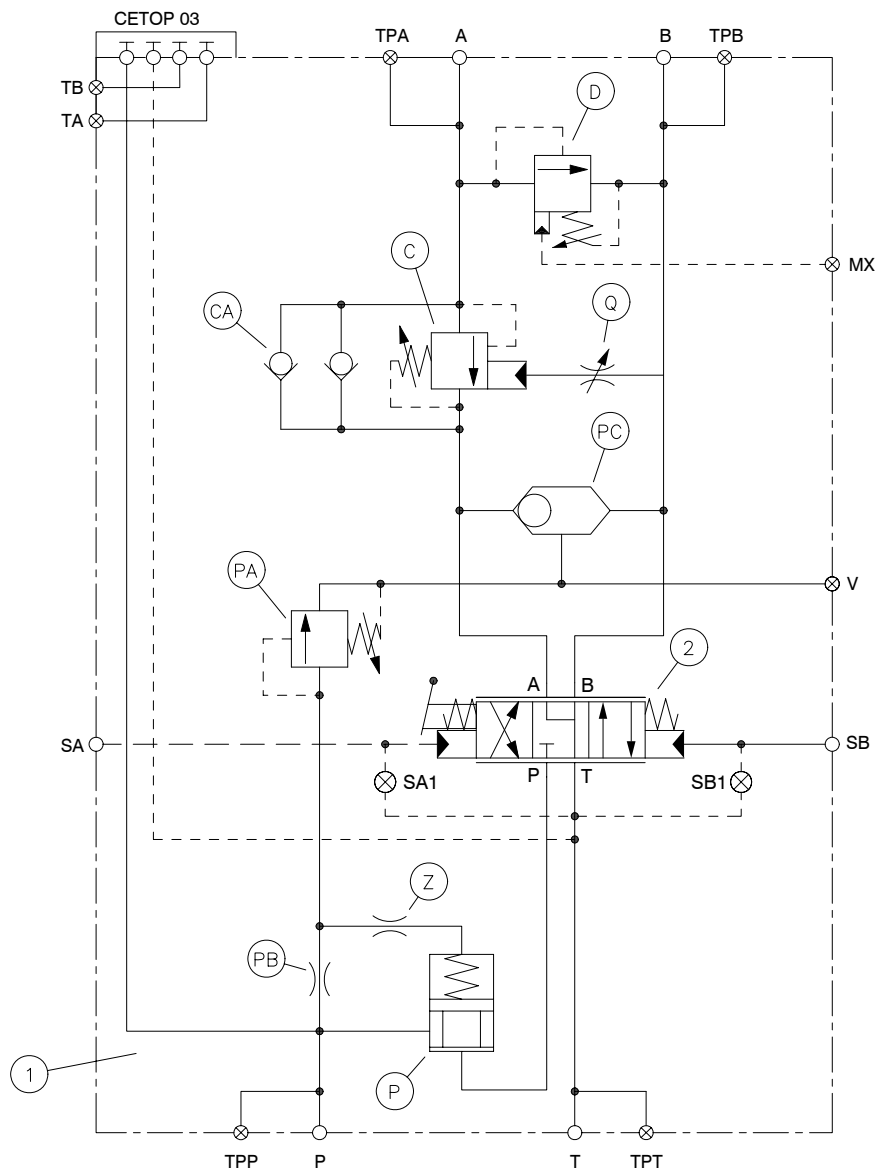

Figure 2 Hydraulic Schematic 8MB-200-37-2C-MA

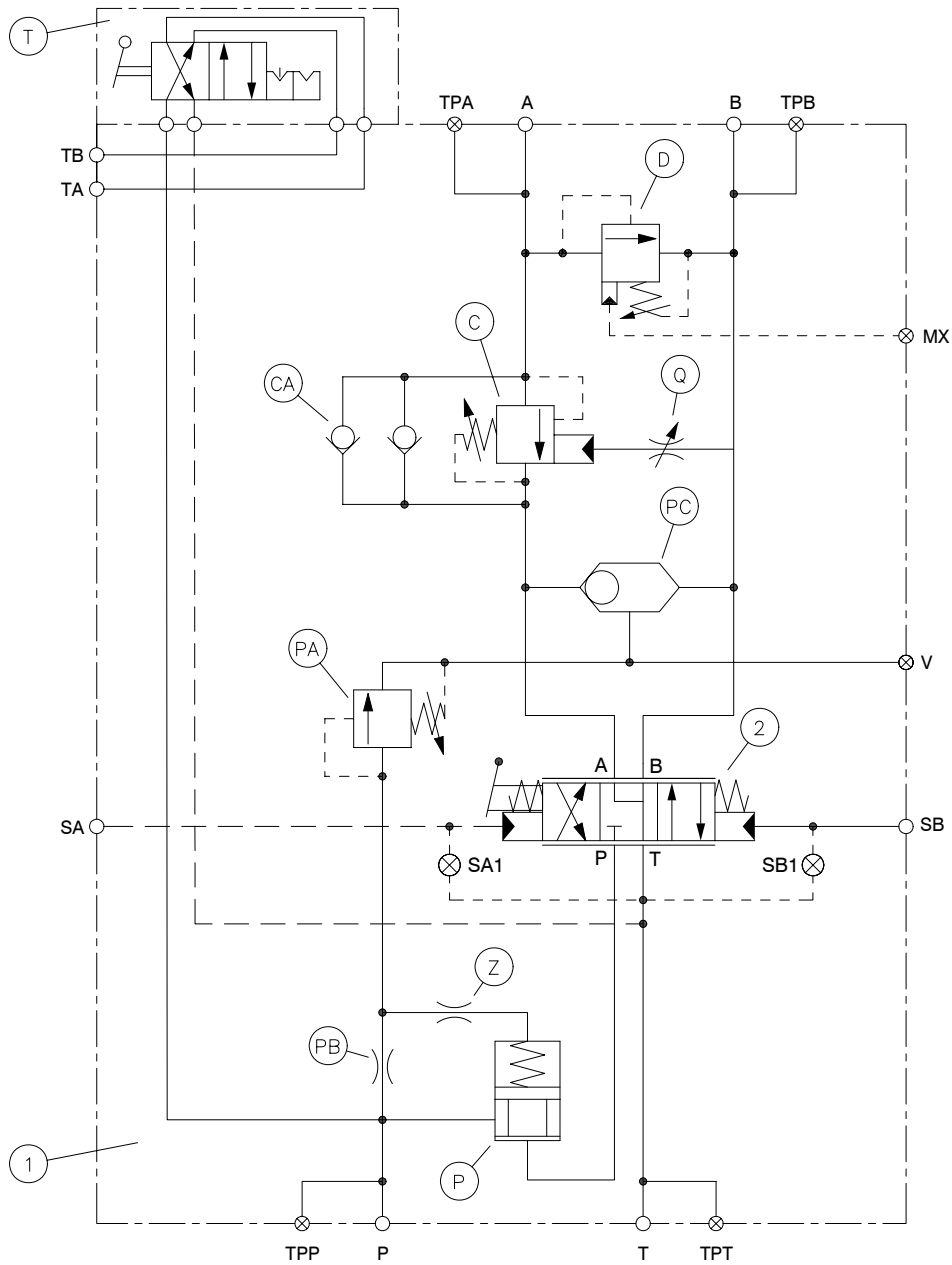

Figure 3 Hydraulic Schematic 8MB-***-37-2C-MA-T

8MB modular unit includes in basic version directional control valve (2), pressure compensation flow control system (P, PB, PA, PC and Z), free flow check valve (CA), load control (C and Q), pressure relief (D).



Item 1 **Main block.**

Item 2 **Directional control valve 4/3.**

This is a three position directional spool valve with hand lever. When activating the directional valve handle, the operator controls the direction and drive speed of the drum. Throttling grooves in the main spool open progressively for flow either to A or B port.

Option code 37:

The directional valve is prepared to be hydraulically proportional remote controlled. Pilot pressure 5-20 bar.

Item C **Counterbalance valve A→T.**

The counter balance valve keeps the load under control during lowering operations.

Throttling grooves in the counter balance spool open progressively for flow from A→T port, and thus give a smooth lowering operation.

Pilot ratio counterbalance valve: 4.5:1

Factory preset to 325 bar.

Item Q **Adjustable throttling.**

Throttling for the counter balance pilot channel. For dampening the counter balance valve if the valve is fluctuating.

Factory preset to ½ turn counter clockwise (ccw) from closed position.

Item CA **Check-valve free flow P→A.**

Bypassing the counter balance valve in Heave.

Item D **Pressure relief valve A→B.**

The pilot operated pressure relief is connected between motor ports A→B to secure the hydraulic motor and limit the maximum pressure.

Pilot operated pressure relief valve will in some application be used as a mooring valve, to keep a constant tension on the drum. Tension pressure can either be adjusted by a hand wheel (option MAM) or remote controlled by port MX.

If presetting is not stated in the order, the pressure relief valve item D is set to its minimum.

**Generally about the pressure compensator system.**

This is a load independent system, which means that a given spool stroke on the directional valve will give equal flow independent of the motor/drum load.

The main directional spool (2) in conjunction with the pressure compensator flow control system (P, PA, PB, PC and Z), regulates the proportional oil flow to either A (Heave rotation) or B (Lower rotation) by sensing the pressure either in A or B line through the shuttle valve (PC). When operating directional valve (2), the spool will open progressively to A or B. The pressure compensation element will maintain equal an Δp across the directional valve. Maximum flow over the main directional valve is depending on the force induced on the pressure compensator element (P). This force is made up of a spring force in the compensator element item (P), and an adjustable spring force in the compensator pilot valve (PA) and the load pressure sensing in A or B via (PC). When the setting is altered on the compensator pilot valve (PA), the flow will change.

When adjusting pressure relief valve PA, the Δp through the directional valve will alter, and thus maximum flow to the hydraulic motor.

- Item PC Shuttle valve for the pressure compensator.**
Port V can be used for load sensing or in some applications for a hydraulically operated brake release valve.
- Item P Pressure compensator element.**
Normally open modulating element, which acts as a pressure compensator to maintain a constant pressure drop across the directional valve (together with PC, PB, PA and Z).
- Item Z Dampening nozzle for the pressure compensator element.**
- Item PB Nozzle.**
Maintains flow to compensator pilot valve PA.
- Item PA Compensator pilot valve.**
The spring is rather weak. Therefore, pressure created by an adjustable pressure relief valve is added to the spring force.

OPTIONS- DESCRIPTION 8MB

- Code 37** Manually/remote operated.
- 1B** Manually operated, with brake release 4BA3
- 37B** Manually/remote operated, with brake release 4BA3.
Ports dimension for brake release valve 4BA3: $\frac{3}{8}$ " BSPP

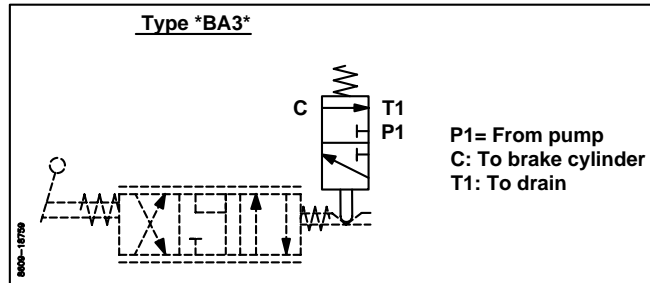

- Code 37E** Manually/Proportionally electrical remote operated.
Proportional reducing valve item E is Hydranor 8FGB4131021-11/11.
Pressure reducing valve not integrated in 8FGB4131021-11/11, but separate sandwich component.

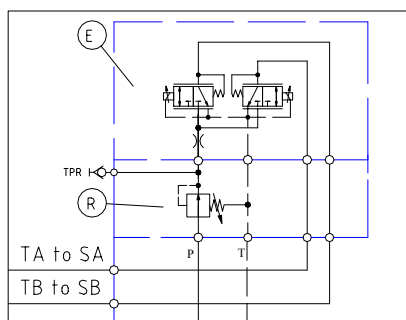

- Code 37ER** Manually/Proportionally electrical remote operated with integrated pressure reducing valve and external drain port D. T from ER to main block is plugged.
- Proportional reducing valve item ER is Hydranor 8FGBR4431021-11/11-D

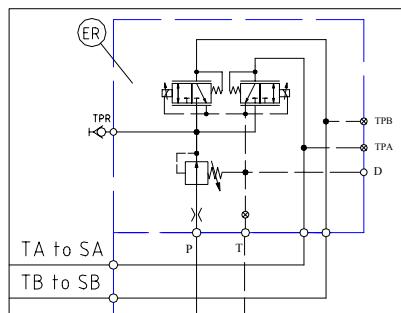

- Code L** Manual control safety lock for locking in 0 position only. This is a mechanical device for preventing operation of the directional valve unless the safety lock is manually released.
For other locking device, see model code L and L3.

Code MAM Mooring valve operated by a hand wheel to control pressure in A.

Code C2 Counterbalance valve in A and B.

Code D2 Pressure relief valves in A (A→B) and B (B→A).

Two-speed valve module:

This is a two position directional spool valve with detent. In most cases to be used for switching two-speed system in the hydraulic motor.

- Code T** Manually operated 4/2-direction valve.
- “ **TR** Manually operated 4/2-direction valve with reduced pressure.
- “ **TH** Hydraulic operated 4/2-direction valve
- “ **THR** Hydraulic operated 4/2-direction valve with reduced pressure.
- “ **TMH** Manually/hydraulic operated 4/2-direction valve .
- “ **TMHR** Manually/hydraulic operated 4/2-direction valve with reduced pressure.

Port connection two-speed system:
TA/TB: 3/8” BSPP

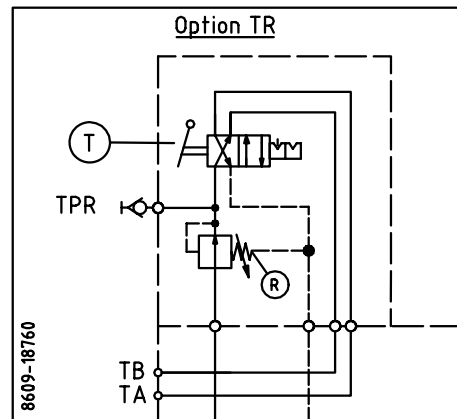

PRESSURE DROP 8MB

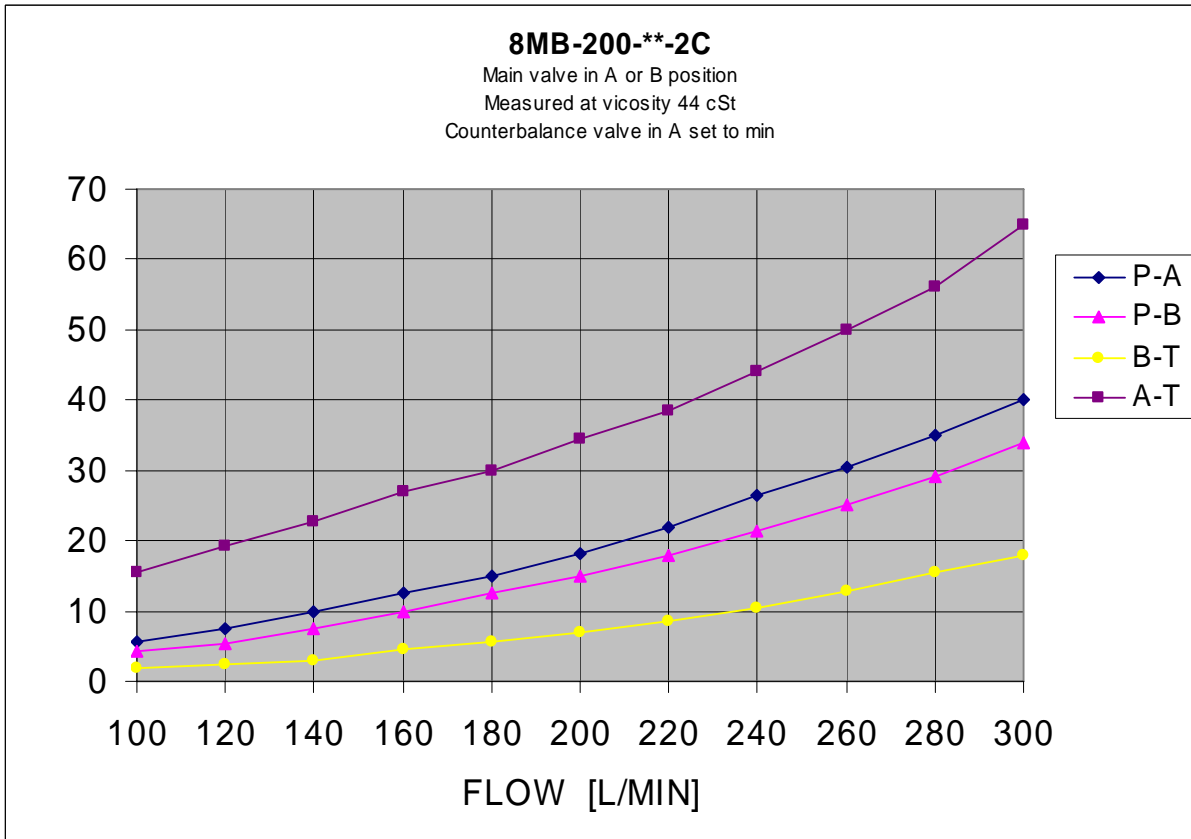

Figure 5 8MB-200-**-2C-MA pressure drop

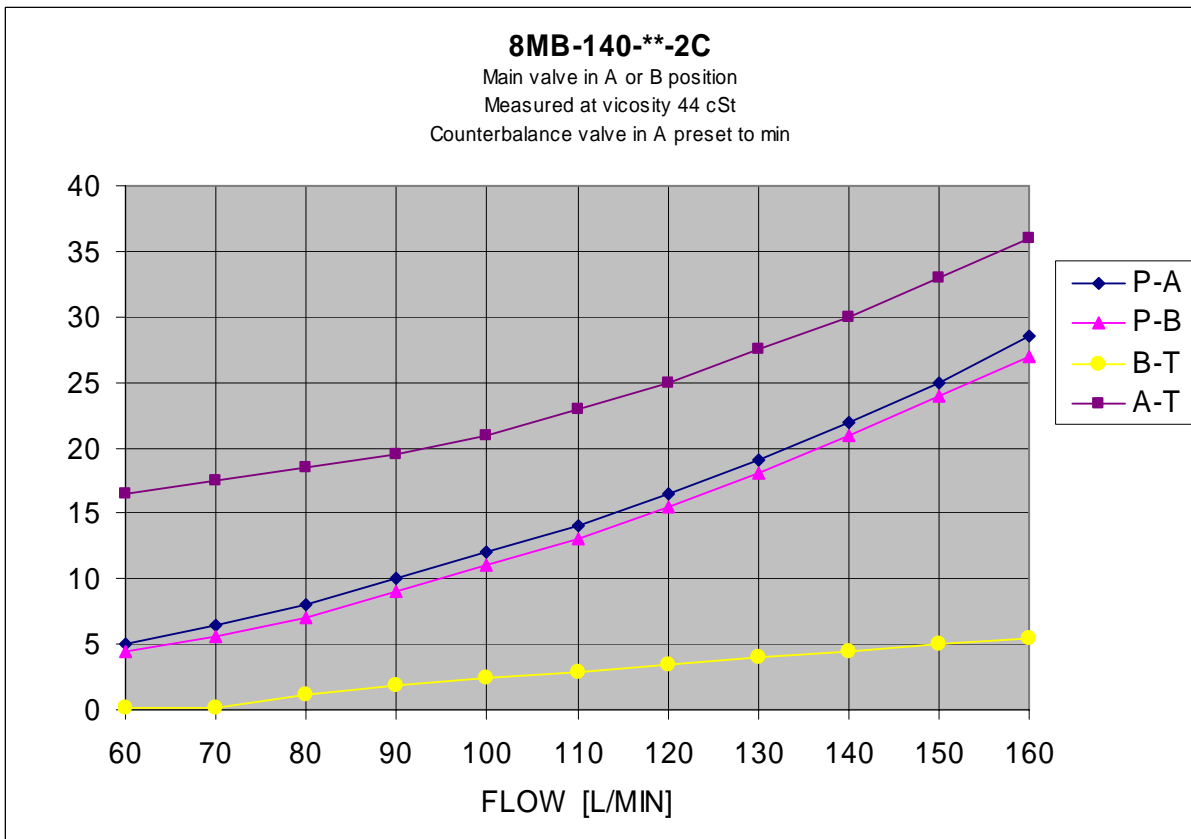

Figure 6 8MB-140-**-2C-MA pressure drop

TECHNICAL DATA

Description	Symbol	Unit	Value	
			8MB-140	8MB-200
Flow (Δp 32 bar)	Q_{max}	l/min	8MB-140	8MB-200
Flow area		l/min	70-140	140-200
Max. operating pressure	P_{max}	bar	315	
Recommended max. pressure in port T. See Note 1.	T_{max}	bar	20	
Directional valve pilot pressure	P	bar	5-20	
Weight basic version	m	kg	≈ 32	
Hydraulic fluid			Mineral oils for hydraulic system	
Viscosity range:	ν	m^2/s	10 to 350 (cST)	
Viscosity index:	VI		> 120	
Filtration, recommended filter with $\beta_{20} \geq 100$			Class 9 according to NAS 1638, 18/15 according to ISO 4406	
Fluid temperature range:	T		-20°C to + 70°C	
Ambient temperature range	T		-20°C to + 50°C	
Standard Body Material			EN-GJS-400-15 (GGG 40)	
Standard O-rings			Nitrile shore 70	

Note1: Be aware that pressure on the tank port T is direct additive to valve setting for pressure relief valve item D, counterbalance valve item C, and pressure reducing valve item R (If selected option R). Pressure peaks in T port can influence on the stability of the system, particular proportional remote control of main directional valve.

Interfaces:

Ports	Port dimension
P	$\frac{3}{4}$ " SAE 6000
T	1" SAE 3000
A, B	$\frac{1}{2}$ " SAE 6000
SA, SB, TA and TB	$\frac{3}{8}$ " BSPP
MX	$\frac{3}{8}$ " BSPP
V, TPP, TPT, TPA and TPB	$\frac{1}{4}$ " BSPP
Mounting Screws:	2 off M 12 (Thread depth 25 mm)



INSTALLATION

The Modular unit 8MB is installed with 2 off screws with thread dimension M12x25 to a bracket, or mounted to a motor flange by an adapter plate. Please refer to 'Interfaces' in section 'TECHNICAL DATA', for details about screws and o-rings.

OPERATION

Manual control is performed by the hand lever. The valve is delivered with a centring spring, which means that the main spool will return to the neutral position after operating the hand lever.

Option 37 (Manual/remote operated):

Directional valve is prepared to be hydraulic proportional remote controlled. An external pilot pressure moves the spool to the requested position Pilot pressure 5-20 bar. The valve is equipped with a hand lever to override the pilot pressure.

VALVE ADJUSTMENTS

If presetting is not stated in the order, the pressure relief valve (item D) is set to its minimum. The counterbalance valve is preset to 325 bar opening pressure. Recommended presetting for the counterbalance valve is 1.3 times the maximum load pressure.

(250 bar load pressure x 1.3 = 325 bar).

Throttling item Q is factory preset to ½ ccw turn from closed position.

MAINTENANCE

Check the valve for proper function. Visually check the valve and if required, paint unpainted (damaged) areas.

CAUTION: Do not paint the hand levers shaft seals.

SPARE PART

Seal Kit Set is available.

STORAGE

If storage longer than 6 months is expected, the valve must be kept in a dry room, free from dust and protected against sudden large temperature variations. For storage longer than 12 months, the valve must be filled with inhibition oil. Before use check all visible seals and flush with clean oil.

MARKING

Inlets and outlets are marked; refer to figure in section 'GENERAL DESCRIPTION'.