

VB40 CONTROL VALVE

GENERAL DESCRIPTION

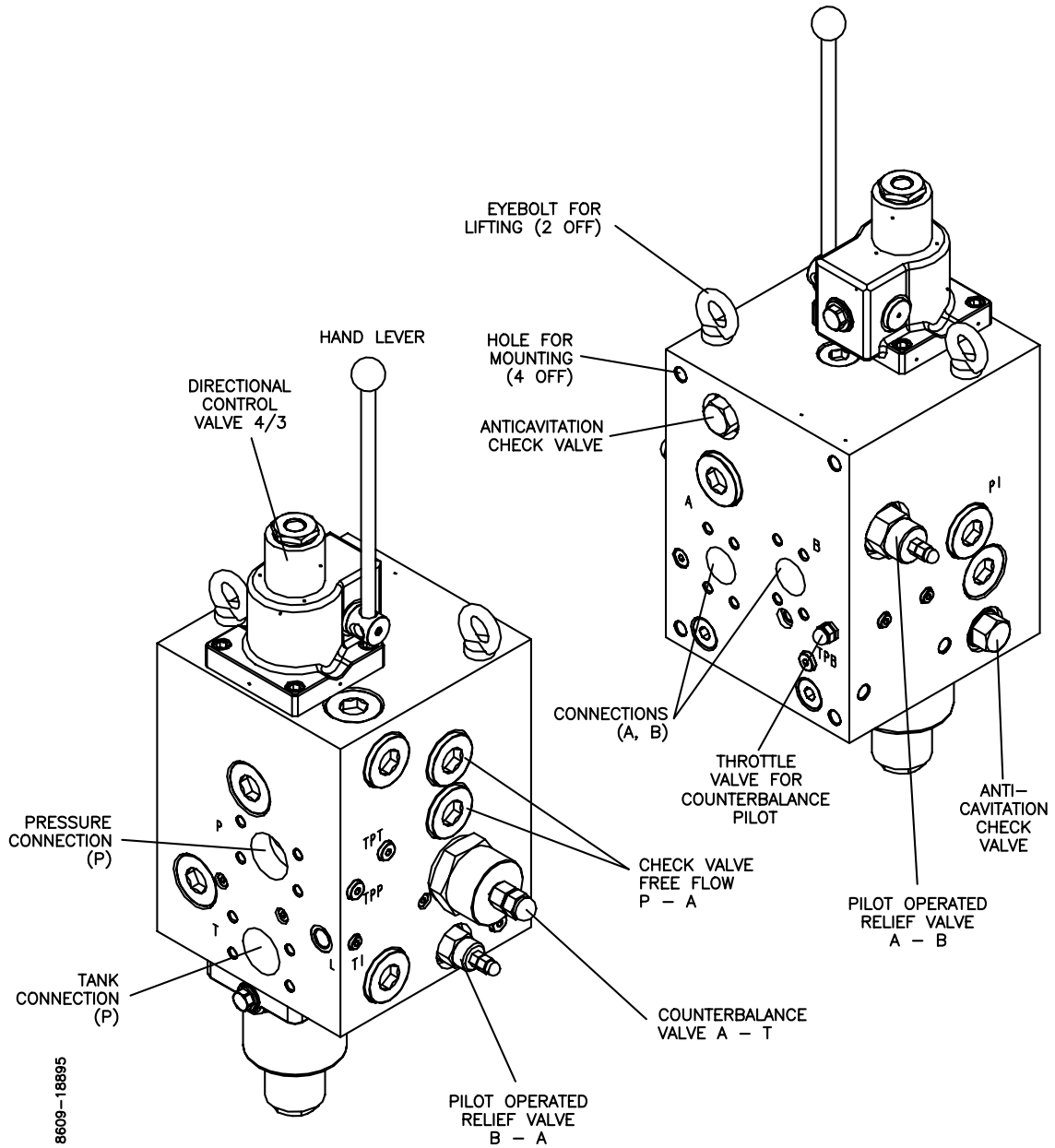

Figure 1 General Arrangement VB40-R-D2-01-AC.

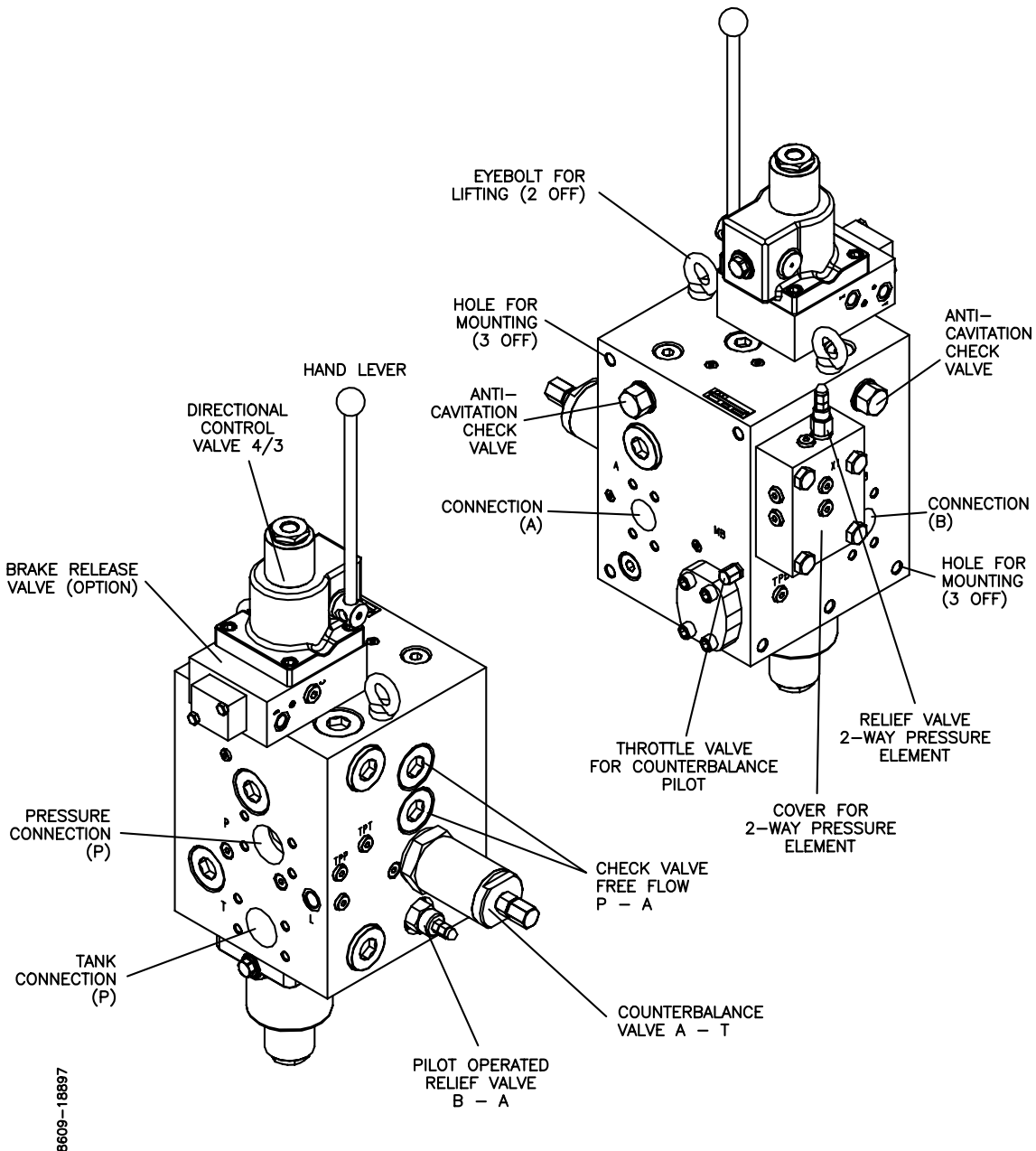

Figure 2 General Arrangement VB40-BR-D2-01-AC-MA-*** .

The Modular Unit VB40 is a complete unit for controlling of hydraulically driven winches and designed for fixed pump systems. VB40 with its integrated functions is special designed for fish and trawl winches.

Advantages with the new design are several:

- Considerably more compact unit/external dimension
- Decreased pressure drop
- Fewer leakage points
- Cost efficiency because of less machining

For more details about types and options, please refer to section 'MODULAR CODE'.

MODULAR CODE

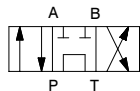
Options	Remarks	Design Code	Fill in
Standard			
- Main block		VB	VB
- Directional Valve			
- Counterbalance valve in A			
-Free flow check valve P to A			
- Pressure relief valve A to B			
- Pressure relief valve B to A			
- Anticavitation valve to A and B			
Size			
Rated flow Q = 900 l/min		40	40
Directional Control Valve 4/3			
Manually operated	Spring centred	1	
Manually/remote operated	Spring centred	R	
Manually operated with brake release 4BA3	Spring centred	B	
Manually/remote operated with brake release 4BA3	Spring centred	BR	
Pressure relief valve			
Pressure relief A to B and B to A		D2	D2
Spool type			
	No option	01	01
Anticavitation valves			
Boosting T to A and B	No option	AC	AC
Remote control tension valve			
Tension control cartridge valve A to B		MA	
Modification			
Code		(001-999)	

In example a VB40 with rated flow Q = 900 l/min, manually operated with brake release, pressure relief A to B and B to A, tension control cartridge A to B will have modular code: **VB40-BR-D2-01-AC-MA-*****



VALVE DESCRIPTION VB40

- Item 1** **Main block.**
- Item 2** **Directional control valve 4/3.**
This is a three position directional spool valve with hand lever. When activating the directional valve handle, the operator controls the direction and drive speed on the drum. Throttling grooves in the main spool opens progressively for flow to either A or B ports.
- Item 3** **Adjustable throttling.**
Throttling for the counter balance pilot channel.
Factory preset to 1/2 turn counter clockwise (ccw) from closed position.
- Item 4** **Check-valve free flow P→A**
Bypassing counter balance valve.
- Item 5** **Counterbalance valve A→T.**
The counter balance valve keeps the load under control during lowering operations.
Throttling grooves in the counter balance spool open progressively for flow from A→T port, and thus give a smooth lowering operation and low pressure rise with full flow. The counterbalance spool opens by a pilot pressure taken from line B.
Factory preset to 40 bar.
- Item 6** **Nozzle: (Option MA)**
Feeding orifice for the pressure control system.
- Item 7** **2-way pressure control element: (Option MA)**
This is a pressure control cartridge of bore size 40. The element is pilot controlled by relief valve item 8, or by external proportional relief valve connected to port X1. The reduced pressure will be used as a mooring valve, to keep a constant tension on the drum, or for freewheeling the hydraulic motor to increase the speed when lowering.
- Item 8** **Relief valve: (Option MA)**
This is a direct acting pressure relief valve intended for remote control of 2 way pressure control element item 7. The relief valve will act as pressure limiter for the system, and will secure the motors and control maximum pull force on the drum.
If presetting is not stated in the order, the pressure relief valves item 8 is set to its minimum.
- Item 9** **Nozzle: (Option MA)**
Dampening orifice for the pressure control cartridge.



Item 10A Pressure relief valve A→B

Pilot operated pressure relief valve for secure the motor.

If presetting is not stated in the order, the pressure relief valve is set to its minimum.

Item 10B Pressure relief valve B→A

Pilot operated pressure relief valve for secure the motor.

If presetting is not stated in the order, the pressure relief valve is set to its minimum.

Item 11/12 Anticavitation check valve (boosting to A and B)

Boosting from T to A and B, to ensure that cavitation not occur. Therefore, a certain flow must be applied to A or B to replace leakage.

DIMENSIONS

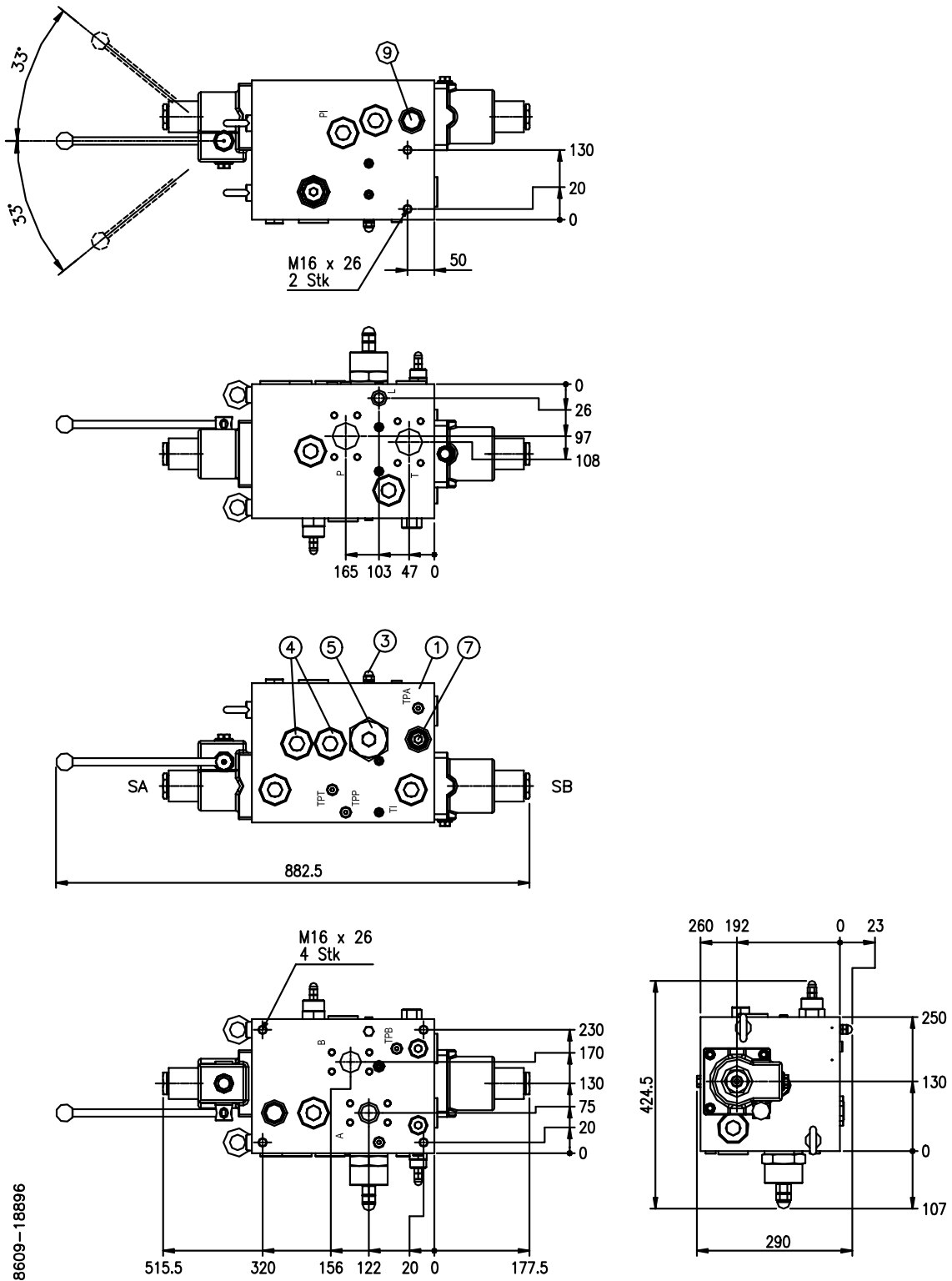

8609-18896

Figure 3 Dimensions VB 40-R-D2-01-AC

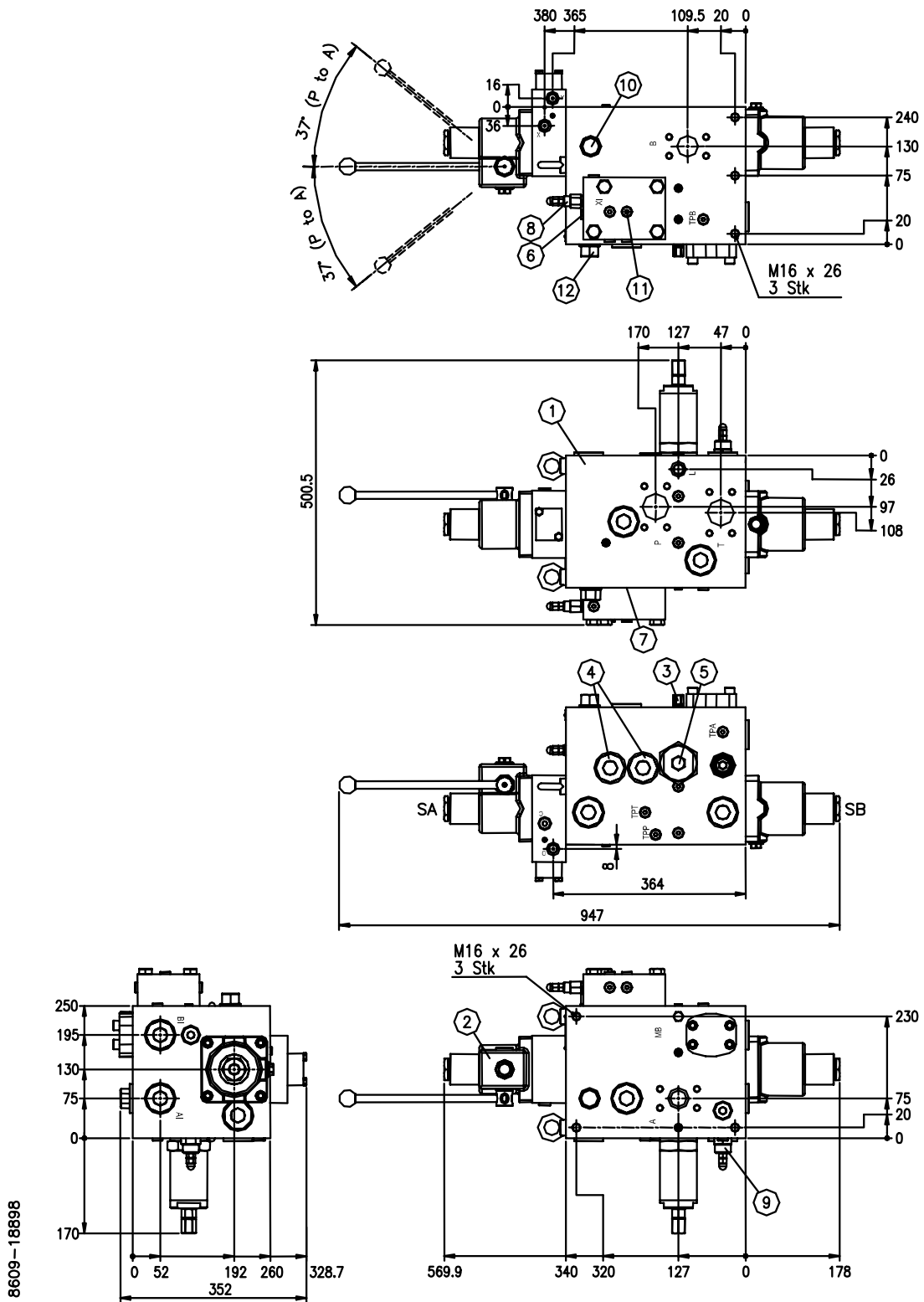

Figure 4 Dimensions VB 40-BR-D2-01-AC-MA-***



PRESSURE DROP VB40

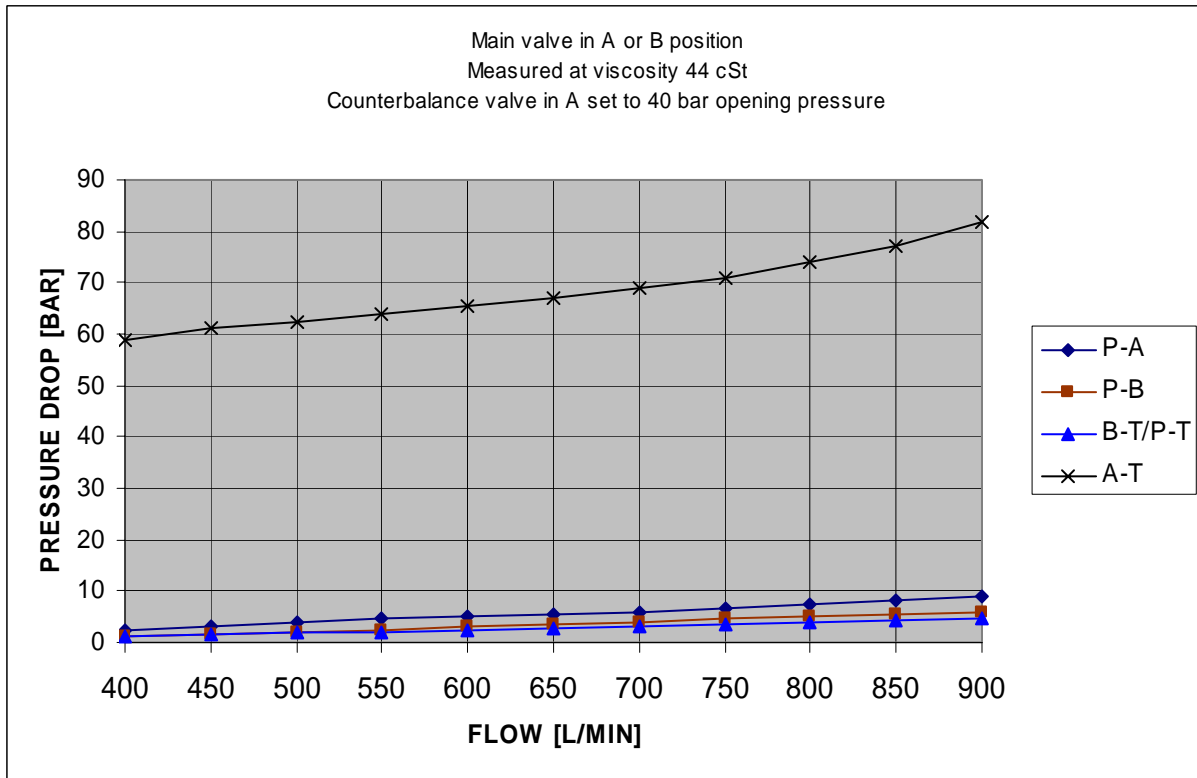

Figure 5 Pressure Drop VB40-R-D2-01-AC

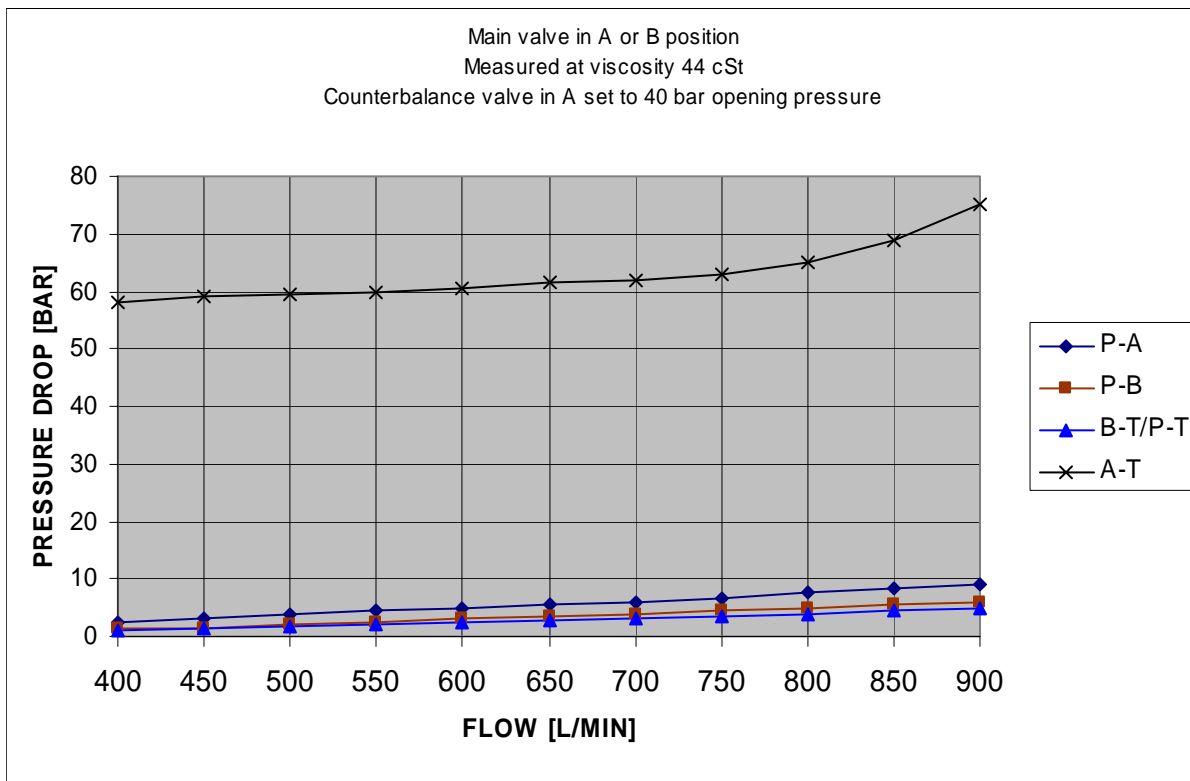

Figure 8 Pressure Drop VB40-R-D2-01-AC-MA-***

TECHNICAL DATA

Description	Symbol	Unit	Value
Flow	Q_{\max}	l/min	900
Max. operating pressure	P_{\max}	Bar	210
Directional valve pilot pressure	P	bar	5-30
Weight basic version	m	kg	$\cong 158$
Hydraulic fluid			Mineral oils for hydraulic system
Viscosity range:	v	m^2/s	10 to 350 (cST)
Viscosity index:	VI		> 120
Filtration, recommended filter with $\beta_{20} \geq 100$			Class 9 according to NAS 1638, 18/15 according to ISO 4406
Fluid temperature range:	T		-20°C to + 70°C
Ambient temperature range	T		-20°C to + 50°C
Standard Body Material			EN-GJS-400-15 (GGG40)
Seals			Buna-N

Interfaces:

Connections			
Ports	Remarks	Dimensions	
		VB40-BR-D2-01	VB40-BR-D2-01-MA-***
P, T		2" SAE 3000	2" SAE 3000
A, B		1 1/2" SAE 3000	1 1/2" SAE 3000
A1, B1	Option MA		1 1/2" BSPP
MB			1 1/2" SAE 3000
X1			1/4" BSPP
L, SA, SB		1/2" BSPP	1/2" BSPP
D, X, Y	Option B	3/8" BSPP	3/8" BSPP
TPP, TPT, TPA, TPB		1/4" BSPP	1/4" BSPP
Mouthing Screws:		3 off M 16 (Thread depth 26 mm)	



INSTALLATION

The VB40 are installed with 3 off screws to a bracket. Please refer to 'Interfaces' in section 'TECHNICAL DATA', for details about screws.

OPERATION

Manual control is performed by the hand lever. The valve is delivered with a centring spring, which means that main spool will return to the neutral position after operating the hand lever.

Option R (Manual/remote operated):

The directional valve is prepared to be hydraulically proportional remote controlled. An external pilot pressure moves the spool to the requested position Pilot pressure 8-30 bar. The valves are equipped with a hand lever for overriding the pilot pressure.

COUNTERBALANCE ADJUSTMENT

The counterbalance valve are preset from factory to 40 bar, which is minimum recommended opening pressure for the counterbalance valve.

Switch directional valve to lower, just so it starts open B. Do not have full deflection on the handle.

Turn adjusting screw clockwise to increase opening pressure for the counter balance valve. Counter balance valve opens when the motor starts to rotate.

When lowering it can occur that the counter balance valve will knock if the dampening is not correct adjusted. When adjusting at the throttle valve item 3 the reaction of the counterbalance valve will change.

Turn screw clockwise to increase dampening.

PRESSURE ADJUSTMENT

Do not have full deflection on the handle when adjust the pressure relief valve.

Turn adjusting screw clockwise to increase pressure setting for the pressure relief valve.

Install a pressure gauge to the valve, and turn the hexagon screw until the requested pressure is achieved. Clockwise rotation will increase pressure setting.

MAINTENANCE

Check the valve for proper function. Visually check the valve and if required, paint unpainted (damaged) areas.

SPARE PART

Spring set and seal set are available.



STORAGE

If storage longer than 6 months is expected, the valve must be kept in a dry room, free from dust and protected against sudden large temperature variations. For storage longer than 12 months, the valve must be filled with inhibition oil. Before use check all visible seals and flush with clean oil.

MARKING

Inlets and outlets are marked, refer to figure in section 'GENERAL DESCRIPTION'.